

PROCESS PLATFORM: CENTURY® C-740 SERIES

SELECTIVE CONFORMAL COATING SYSTEM AUTOMATED CONFORMAL COATING APPLICATION

The Century® C-740 Series Selective Conformal Coating system provides consistent, uniform dispensing of a variety of conformal coating materials for both batch and inline coating applications. Patented dispensing technology replaces traditional dip, brush, handgun, and aerosol spray systems with field-proven, repeatable delivery of solvent-based and 100-percent solids materials. The system virtually eliminates the requirement for labor-intensive board masking, providing accurately controlled patterns, film builds, and production flexibility in an automated process.

Equipped with Easy Coat® for Windows NT® (ECNT) software, uniquely designed for conformal coating applications, the system offers increased coating flexibility within a familiar Windows environment. Multiple coating commands can be edited simultaneously, minimizing the time required to make programming and pattern changes. Conformal coating log files are configurable, allowing users to record system events and parameters for process improvement and analysis.

The system's tri-mode Swirl Coat™ module is ideal for conformal coating a high mix of circuit boards using a wide range of 100-percent solids materials with viscosities from 30 to 3,500 centipoise. By varying the volume, dispensing pressure, and the use of shaping air jets, conformal coating material can be dispensed in a bead, monofilament, or swirl pattern. The system's ECNT software allows coating modes to be changed on-the-fly in a single coating cycle, without interrupting the coating sequence.

For application of solvent-based and 100-percent solids materials, the film coater module provides automated, selective application of materials with viscosities of less than 100 centipoise. Complex circuit boards requiring multiple pattern widths and film builds are coated in seconds, with up to 100-percent transfer efficiency.

Several options can be added to the dispensing system to meet specific application requirements, including a chain conveyor, fan width control, bar code recognition system, and light curtain. Options for two-sided conformal coating include an inline board inverter. For reliable curing of conformal coating materials, an IR/convection module is available in four heating lengths.



FEATURES:

- Cost-effective selective application of conformal coating materials virtually eliminates extensive masking and rework, maximizing throughput
- Easy Coat for Windows NT software, uniquely designed for conformal coating application, offers flexibility beyond generic motion control/dispensing packages
- The tri-mode Swirl Coat module delivers from 0.25 to over 20 mils of 100-percent solids materials in a single pass
- The Film Coater module provides precise, non-atomizing coating of complex circuit boards with up to 100-percent transfer efficiency
- Compact footprint (1 m²) conserves factory floor space

CENTURY C-740 SYSTEM SPECIFICATIONS:

MOTION SYSTEM:

Type:	Brushless DC Stepper Motor
X-Y Velocity:	508 mm/s (20 in./s) maximum 381 mm/s (15 in./s) default
Z-Axis Velocity:	203 mm/s (8 in./s)
X-Y Repeatability:	±0.025 mm (0.001 in.), 3 sigma
Z-Axis Repeatability:	±0.025 mm (0.001 in.), 3 sigma
X-Y Resolution:	±0.025 mm (0.001 in.), 3 sigma
Z-Axis Resolution:	±0.025 mm (0.001 in.), 3 sigma
Positional Accuracy:	±0.13 mm (0.005 in.), 3 sigma

DISPENSE AREA:

Inline:	458 x 432 mm (18 x 17 in.)
Batch:	458 x 458 mm (18 x 18 in.)

Note: Purge and solvent cups reduce available coating area

CONVEYOR:

Inline:	Belt conveyor with lift/clamps Manual width adjustment from 51 to 457 mm (2 to 18 in.) Conveyor speed programmable to 254 mm/s (10 in./s)
---------	-------------------------------------------------------------------------------------------------------------------------------------------------------

Maximum Component Clearance:	89 mm (3.5 in.) top and bottom side
------------------------------	-------------------------------------

Maximum Pallet/PCB Weight:	2 kg (5.5 lbs.)
Batch:	Tooling plate; 508 x 508 mm (20 x 20 in.)

COMPUTER:

Computer:	Pentium® PC
User Interface:	Monitor, keyboard and mouse

SOFTWARE:

User Environment:	Easy Coat® for Windows NT®
Operating System:	Windows NT

FLUID DELIVERY METHOD:

SC-105 Film Coater module:	Non-atomizing, heat-circulating system
SC-205 Film Coater module:	Non-atomizing, non-circulating system
Swirl Coat™ module:	Tri-mode swirl system

OTHER STANDARD FEATURES:

Purge and solvent cups
Ventilation controls
Door interlock controls
Light beacon

FACILITIES REQUIREMENTS:

System Footprint:	917 x 1041 mm (36 x 41 in.)
Air Supply:	620 kPa (90 psi, 6.9 Bar), up to 85 l/min (3 SCFM) maximum depending on configuration
Ventilation Air:	0.28 m ³ /s @ 25 mm water column (600 SCFM @ 1.0 in. water column)
Nitrogen Source:	Required for moisture-sensitive materials – 410 kPa (60 psi, 4.1 Bar) @ 1 l/min (0.5 SCFM)
Power (Mains):	100/120/220/240 VAC, 50/60 Hz, 10 A
Noise:	< 70 dBA
System Weight:	295 kg (650 lbs.)
Standards Compliance:	SMEMA CE

OPTIONAL FEATURES:

Chain conveyor with board pins (inline only)
IR/convection curing module
Fan Width Control system for SC-105/205 Film Coater modules
Bar code recognition system
Standalone board inverter module
Dual gun capability
Light curtain
Laser pointer programming aid
Low fluid sensor

Please contact these locations for the name of your local representative:

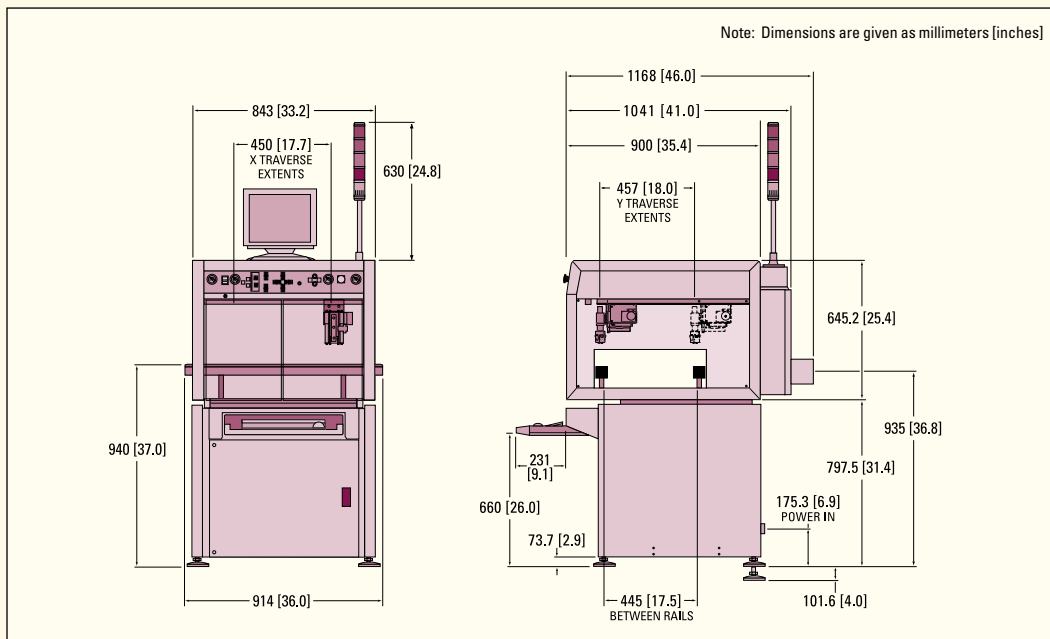

HEADQUARTERS

2762 Loker Avenue West
Carlsbad, CA 92008-6603 USA
U.S. (toll free): 1-800-ASYMTEK
Tel: (760) 431-1919
Fax: (760) 431-2678
Email: info@asymtek.com

INTERNATIONAL SALES

Europe: +31 (0) 43-352-4466
Japan: +81 (0) 3-5762-2801
Korea: +82-31-766-8321
S.E. Asia: +65 (0) 7782511
Taiwan: +886-2-82001268

www.asymtek.com

Century®, Fluidmove®, and Asymtek® are trademarks of Asymtek.
Swirl Coat®, Easy Coat®, and Nordson® are trademarks of Nordson Corporation.
Windows NT® is a registered trademark of Microsoft, Inc.
Pentium® is a registered trademark of Intel.

Asymtek reserves the right to make design changes to products to improve their function. These changes may occur between printings.

Contact Asymtek for your specific application requirements.